

# 上海沪生电子产品使用说明书

<http://www.husoon.com>

电话：021-61021969

网站：www.husoon.com

## Features

- Allows PC users to perform the following functions:
  - Program MAX® 9000, MAX 7000S, MAX 7000A, MAX 3000A devices in-system via a standard parallel port
  - Configure APEX™ 20K, FLEX® 10K (including FLEX 10KA and FLEX 10KE), FLEX 8000, and FLEX 6000 devices
- Supports operation while powered up with  $V_{CC}$  at 3.3 V or 5.0 V
- Provides a fast and low-cost method for in-system programming
- Downloads data from the MAX+PLUS® II development software
- Interfaces with a standard 25-pin parallel port on PCs
- Uses a 10-pin circuit board connector, which is identical to that of the ByteBlaster™ parallel port and BitBlaster™ serial download cables

## Functional Description

The ByteBlasterMV™ parallel port download cable (ordering code: PL-BYTEBLASTERMV) is a hardware interface to a standard PC parallel port (also known as an LPT port). This cable drives configuration data to APEX 20K, FLEX 10K (including FLEX 10KA and FLEX 10KE), FLEX 8000, and FLEX 6000 devices, as well as programming data to MAX 9000, MAX 7000S, MAX 7000A, and MAX 3000A devices. Because design changes are downloaded directly to the device, prototyping is easy and multiple design iterations can be accomplished in quick succession. See [Figure 1](#).

*Figure 1. ByteBlasterMV Parallel Port Download Cable*

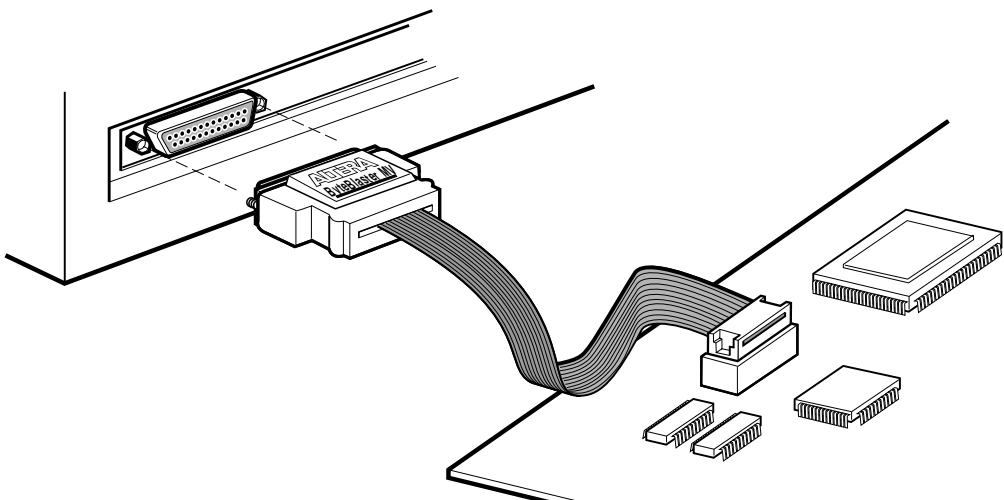

## Download Modes

The ByteBlasterMV cable provides two download modes:

- Passive serial (PS) mode—Used for configuring APEX 20K, FLEX 10K, FLEX 8000, and FLEX 6000 devices
- JTAG mode—Industry-standard Joint Test Action Group (JTAG) interface for programming or configuring APEX 20K, FLEX 10K, MAX 9000, MAX 7000S, MAX 7000A, and MAX 3000A devices

## ByteBlasterMV Connections

The ByteBlasterMV cable has a 25-pin male header that connects to the PC parallel port, and a 10-pin female plug that connects to the circuit board. Data is downloaded from the PC's parallel port through the ByteBlasterMV cable to the circuit board via the connections discussed in this section.

 To configure 2.5-V APEX 20K and FLEX 10KE devices using the ByteBlasterMV download cable, connect the pull-up resistors to a 3.3-V power supply, the cable's VCC pin to a 3.3-V power supply, and the device's VCCINT pin to a 2.5-V power supply. For PS configuration, the device's VCCIO pin must be connected to a 2.5-V or 3.3-V power supply. The ByteBlasterMV VCC pin must be connected to 3.3 V for either APEX 20K and FLEX 10KE JTAG configuration, or MAX 7000A and MAX 3000A JTAG in-system programming. The device VCCIO pin can be connected to either a 2.5-V or 3.3-V power supply.

### ByteBlasterMV Header & Plug Connections

The 25-pin male header connects to a parallel port with a standard parallel cable. [Table 1](#) identifies the pins and the download modes.

Pin	PS Mode Signal Name	JTAG Mode Signal Name
2	DCLK	TCK
3	nCONFIG	TMS
8	DATA0	TDI
11	CONF_DONE	TDO
13	nSTATUS	—
15	VCC	VCC
18 to 25	GND	GND

Figure 2 shows a schematic of the ByteBlasterMV download cable.

Figure 2. ByteBlasterMV Schematic

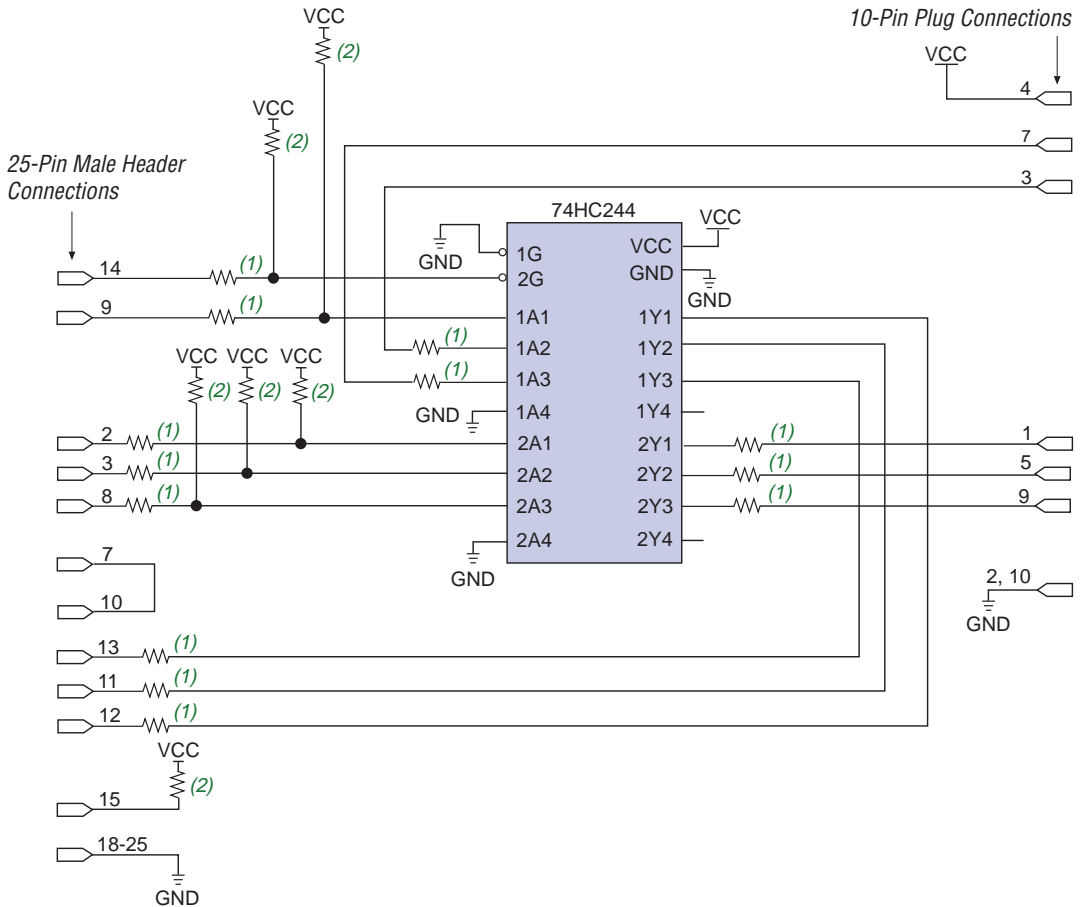

**Notes:**

- (1) All series resistors are 100 Ω.
- (2) All pull-up resistors are 2.2 KΩ.

The 10-pin female plug connects to a 10-pin male header on the circuit board containing the target device(s). Figure 3 shows the dimensions of the female plug.

**Figure 3. ByteBlasterMV 10-Pin Female Plug Dimensions**

Dimensions are shown in inches. The spacing between pin centers is 0.1 inch.

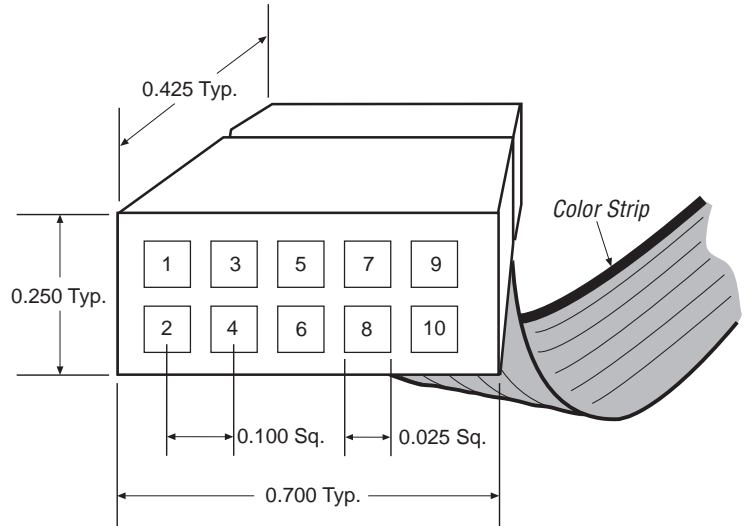

Table 2 identifies the 10-pin female plug's pin names for the corresponding download mode.

Pin	PS Mode		JTAG Mode	
	Signal Name	Description	Signal Name	Description
1	DCLK	Clock signal	TCK	Clock signal
2	GND	Signal ground	GND	Signal ground
3	CONF_DONE	Configuration control	TDO	Data from device
4	VCC	Power supply	VCC	Power supply
5	nCONFIG	Configuration control	TMS	JTAG state machine control
6	–	No connect	–	No connect
7	nSTATUS	Configuration status	–	No connect
8	–	No connect	–	No connect
9	DATA0	Data to device	TDI	Data to device
10	GND	Signal ground	GND	Signal ground



The circuit board must supply  $V_{CC}$  and ground to the ByteBlasterMV cable.

### Circuit Board Header Connection

The ByteBlasterMV 10-pin female plug connects to a 10-pin male header on the circuit board. The 10-pin male header has two rows of five pins, which are connected to the device’s programming or configuration pins. The ByteBlasterMV cable receives power and downloads data via the male header. Figure 4 shows the dimensions of a typical 10-pin male header.

**Figure 4. 10-Pin Male Header Dimensions**

Dimensions are shown in inches.

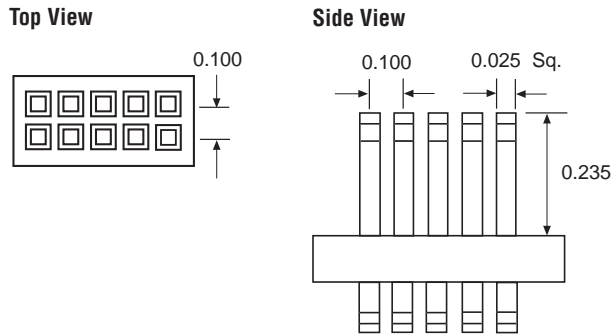

## Operating Conditions

The Tables 3 through 5 summarize the absolute maximum ratings, recommended operating conditions, and DC operating conditions for the ByteBlasterMV cable.

**Table 3. ByteBlasterMV Cable Absolute Maximum Ratings**

Symbol	Parameter	Conditions	Min	Max	Unit
V <sub>CC</sub>	Supply voltage	With respect to ground	-0.5	7.0	V
V <sub>I</sub>	DC input voltage	With respect to ground	-0.5	7.0	V

**Table 4. ByteBlasterMV Cable Recommended Operating Conditions**

Symbol	Parameter	Conditions	Min	Max	Unit
V <sub>CC</sub>	Supply voltage, 5.0-V operation		4.5	5.5	V
	Supply voltage, 3.3-V operation		3.0	3.6	V

**Table 5. ByteBlasterMV Cable DC Operating Conditions**

Symbol	Parameter	Conditions	Min	Max	Unit
$V_{IH}$	High-level input voltage	$V_{CC} = 4.5\text{ V}$	3.15		V
		$V_{CC} = 3.0\text{ V}$	2.1		
$V_{IL}$	Low-level input voltage	$V_{CC} = 4.5\text{ V}$		1.35	V
		$V_{CC} = 3.0\text{ V}$		0.9	
$V_{OH}$	5.0-V high-level TTL output voltage	TTL load. $V_{CC} = 4.5\text{ V}$ , $I_{OH} = 8\text{ mA}$	3.80		V
	3.3-V high-level TTL output voltage	TTL load. $V_{CC} = 3.0\text{ V}$ , $I_{OH} = 4\text{ mA}$	2.48		V
	5.0-V high-level CMOS output voltage	CMOS load. $V_{CC} = 4.5\text{ V}$ , $I_{OH} = 50\text{ }\mu\text{A}$	4.4		V
	3.3-V high-level CMOS output voltage	CMOS load. $V_{CC} = 3.0\text{ V}$ , $I_{OH} = 50\text{ }\mu\text{A}$	2.9		V
$V_{OL}$	5.0-V low-level TTL output voltage	TTL load. $V_{CC} = 4.5\text{ V}$ , $I_{OL} = 8\text{ mA}$		0.44	V
	3.3-V low-level TTL output voltage	TTL load. $V_{CC} = 3.0\text{ V}$ , $I_{OL} = 4\text{ mA}$		0.44	V
	5.0-V low-level CMOS output voltage	CMOS load. $V_{CC} = 4.5\text{ V}$ , $I_{OL} = 50\text{ }\mu\text{A}$		0.1	V
	3.3-V low-level CMOS output voltage	CMOS load. $V_{CC} = 3.0\text{ V}$ , $I_{OL} = 50\text{ }\mu\text{A}$		0.1	V
$I_{CC}$	Operating current			50	mA

## Software Instructions

The MAX+PLUS II Programmer downloads configuration or programming data for FLEX 10K, FLEX 8000, FLEX 6000, MAX 9000, MAX 7000S, MAX 7000A, or MAX 3000A devices.



For Quartus™ Programmer instructions, please refer to Quartus Help.

To configure or program one or more devices with the ByteBlasterMV cable and the MAX+PLUS II Programmer, follow these steps:

1. Compile a project. The MAX+PLUS II Compiler automatically generates an SOF for FLEX 10K, FLEX 8000, and FLEX 6000 device configuration, or a POF for MAX 9000, MAX 7000S, MAX 7000A, and MAX 3000A device programming.
2. Attach the ByteBlasterMV cable to a parallel port on a PC and insert the 10-pin female plug into the prototype system containing the target device. The board must supply power to the ByteBlasterMV cable.



For the Windows NT operating system, a driver must be installed before using the ByteBlasterMV cable. Go to the *MAX+PLUS II Getting Started Manual* for instructions on installing ByteBlasterMV drivers.

3. Open the MAX+PLUS II Programmer. Choose the **Hardware Setup** command (Options menu) to specify the ByteBlasterMV cable and the appropriate LPT port. See “Changing the Hardware Setup” in MAX+PLUS II Help for more information.



The MAX+PLUS II software automatically loads the programming file for the current project (either a POF or SOF), or the first programming file for a multi-device project. To specify another programming file, choose **Select Programming File** (File menu) and specify the correct file. For a FLEX 10K, FLEX 8000, or FLEX 6000 device, select an SOF; for a MAX 9000, MAX 7000S, MAX 7000A, or MAX 3000A device, select a POF.

4. For JTAG or FLEX-chain programming or configuration, perform the following steps:

- ✓ To program or configure devices in a JTAG chain (multi- or single-device chain), turn on **Multi-Device JTAG-Chain** (JTAG menu) and choose **Multi-Device JTAG Chain Setup** to set up the multi-device JTAG chain. See “Setting up Multi-Device JTAG Chains” in MAX+PLUS II Help for more information.



If the JTAG chain includes either FLEX or MAX devices exclusively, set up and create just one JTAG Chain File (.jcf). Likewise, if the JTAG chain includes a mixture of FLEX and MAX devices, set up and create two separate JCFs. One JCF will configure the FLEX devices, and the other JCF will program the MAX devices.

- ✓ To configure multiple devices in a FLEX chain, turn on **Multi-Device FLEX Chain** (FLEX menu) and choose **Multi-Device FLEX Chain Setup** to set up the multi-device FLEX chain. See “Setting Up Multi-Device FLEX Chains” in MAX+PLUS II Help for more information.

5. Choose the **Program** or **Configure** button to program or configure the device(s).

The ByteBlasterMV cable downloads the data from the SOF or POF File(s) into the device(s).

## Conclusion

Downloading configuration and programming data directly to the device via the ByteBlasterMV cable allows designers to verify multiple design iterations in quick succession, thereby speeding the design cycle.

## References

For more information on configuration and in-system programmability (ISP), see the following sources:

- [Application Note 116 \(Configuring APEX 20K, FLEX 10K & FLEX 6000 Devices\)](#)
- [Application Note 33 \(Configuring FLEX 8000 Devices\)](#)
- [Application Note 38 \(Configuring Multiple FLEX 8000 Devices\)](#)
- [Application Note 39 \(IEEE 1149.1 \(JTAG\) Boundary-Scan Testing in Altera Devices\)](#)
- [Application Note 95 \(In-System Programmability in MAX Devices\)](#)
- Search for “Configuring a Single Device with the BitBlaster, ByteBlaster, or FLEX Download Cable,” “Setting Up Multi-Device JTAG Chains,” “Configuring Multiple Devices in a JTAG Chain with the BitBlaster or ByteBlaster,” and “Programming Multiple Devices in a JTAG Chain with the BitBlaster or ByteBlaster” in MAX+PLUS II Help.

## Revision History

The information contained in the *ByteBlasterMV Parallel Port Download Cable Data Sheet* version 1.01 supersedes information published in previous versions. The *ByteBlasterMV Parallel Port Download Cable Data Sheet* version 1.01 contains the following changes:

- Information on APEX 20K and MAX 3000A devices were added throughout the document.
- JTAG configuration information for APEX 20K and FLEX 10KE devices was updated in the “[ByteBlasterMV Connections](#)” section on [page 2](#).
- JTAG ISP configuration information for MAX 7000A and MAX 3000A devices was added to the “[ByteBlasterMV Connections](#)” section on [page 2](#).
- The “Passive Serial Mode” section was removed. This information is found in [Application Note 116 \(Configuring APEX 20K, FLEX 10K & FLEX 6000 Devices\)](#).
- The “JTAG Mode” section was removed. This information is found in [Application Note 39 \(IEEE 1149.1 \(JTAG\) Boundary-Scan Testing in Altera Devices\)](#) and [Application Note 95 \(In-System Programmability in MAX Devices\)](#).
- The Quartus software was added to the “[Software Instructions](#)” section.
- The “[References](#)” section was added, and provides sources for additional information on the ByteBlasterMV download cable.
- Minor textual, illustration, and style changes were made to the data sheet.

Copyright © 1995, 1996, 1997, 1998, 1999 Altera Corporation, 101 Innovation Drive, San Jose, CA 95134, USA, all rights reserved.

By accessing this information, you agree to be bound by the terms of Altera's Legal Notice.